



SERVICE AND BOOT DOOR

INSTALLATION MANUAL





Read this installation instruction thoroughly.
Incorrect installation or operation may void any warranty.
Incorrect use or operation may cause serious injury.

PRODUCT INTRODUCTION

Aussie Traveller's range of service doors feature robust aluminium frames, insulated panels and keyed locks. The door fully opens to allow easy access and can be keyed alike with our DC door. Perfect for outside kitchens, barbeques, fridges and generators

FEATURES:

- Powder-coated aluminium frame available in black or white
- Internally powder-coated aluminium with foam insulation (no external cladding)
- Self-tightening key-locked handle that can be keyed alike with Aussie Traveller's DC door
- Twin-Lock options
- Aluminium hinge available in top, bottom or side hinged configuration
- Door hinge can open 180 degrees to allow maximum access
- 4 rounded corners

SPECIFICATIONS:

- Sizes quoted are height x width and are overall internal frame sizes
- Required Wall Cut-outs are H+3 x W+3
- Corner radius 68mm
- Please note actual door opening is H-50 x W-50

STANDARD PACKING LIST:

Door Piece - Inner & Outer Frame and Inner Door Piece
Brackets & Screw
Door Handle(s) and Key Barrel(s) with 1 key
Rubber Seal
Clip
User Manual

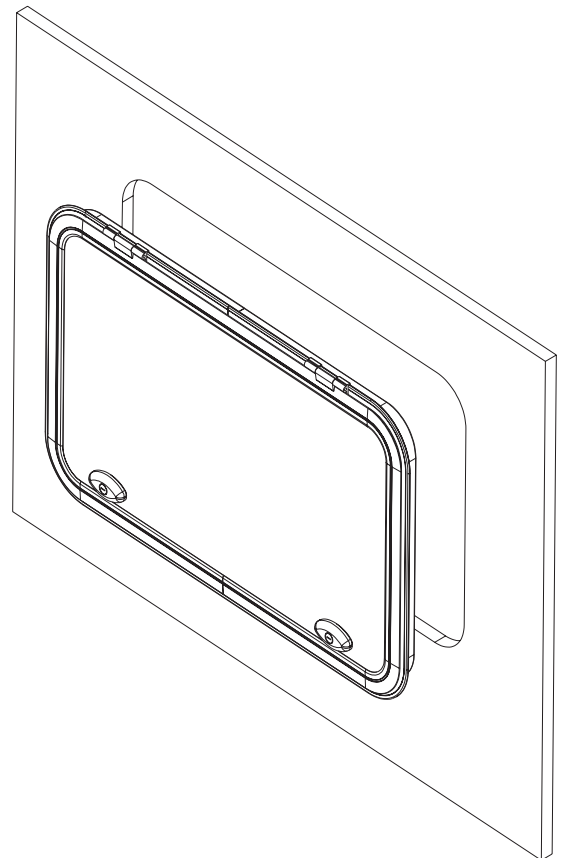

1300 663 868 | enquiries@aussietraveller.com.au | aussietraveller.com.au

BRISBANE SHOWROOM: 11-15 Oasis Court, Clontarf QLD 4019 | MELBOURNE SHOWROOM: 235 Barry Road, Campbellfield VIC 3061

INSTALLATION

1. WALL CUTOUT & OPEN AREA MEASUREMENT:

Check if the side wall is absolutely straight. Ensure the cut out area for the door measures $(H+3) \times (W+3)$ mm with radius of 68 mm on both upper and bottom corners relative to the door to be installed.

- Example SD004-500x800, the measures of the cutout is $H+3=503$, $W+3=803$, R68. (Figure 1a)
- Example SD004-500x800, the measures of the DOOR OPENING is $H-50=450$, $W-50=750$, R68.

RECOMMENDATION: If the sidewall prepared with PU – foam material, the space needs to be packed out. To avoid bulges at the side wall, the packing pieces should match the internal dimensions of the wall (Figure 1b).

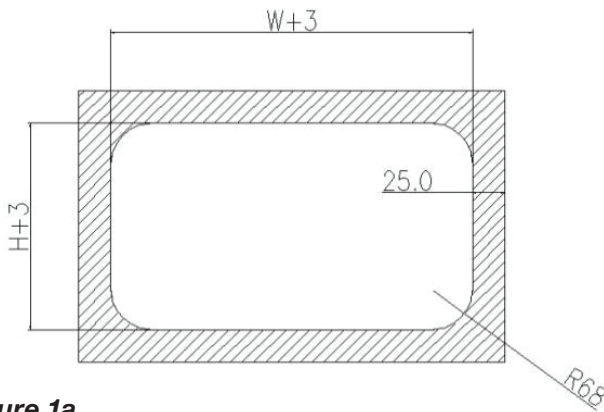

Figure 1a.

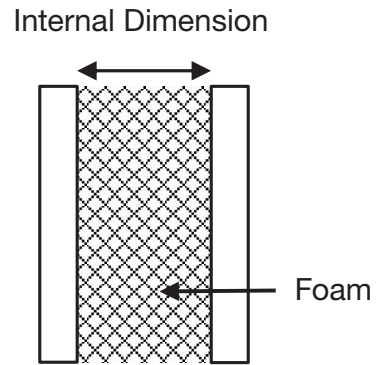

Figure 1b.

2. INSTALLATION OF THE DOOR FRAME:

Start by adding sealant to the frame inner face and the around then edge of the aluminum frame (Figure 2). Immediately set the frame into the sidewall and press it several times in different positions. Whilst the door is being held firmly in position, carefully clamp or a 2nd person hold the door to fasten into position (Figure 3).

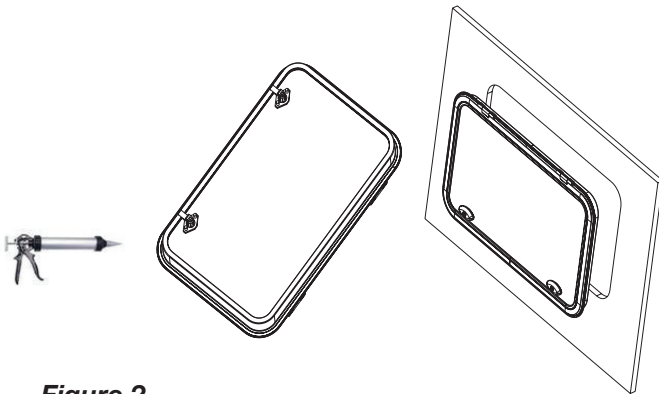

Figure 2

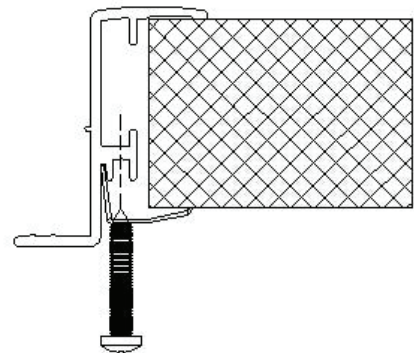

Figure 3

1300 663 868 | enquiries@aussietraveller.com.au | aussietraveller.com.au

BRISBANE SHOWROOM: 11-15 Oasis Court, Clontarf QLD 4019 | MELBOURNE SHOWROOM: 235 Barry Road, Campbellfield VIC 3061

2. INSTALLATION OF THE DOOR FRAME: (CONT.)

Clean any excess sealant away from the external and internal frame.

Drill the frame to match the location of the holes in the hinges, then fix the frame and hinges to the side wall (Figure 4). All holes should be sealed with the sealant before fixing.

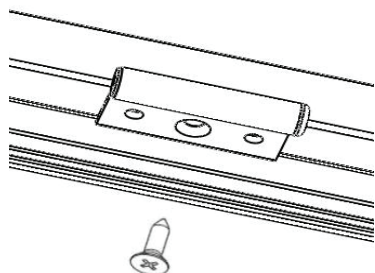

Figure 4

NOTE:

1. There are three sizes of bracket to suit different walls.
2. If the sidewall is too thick, the frame can be installed like (Figure 5) or glue it to the wall

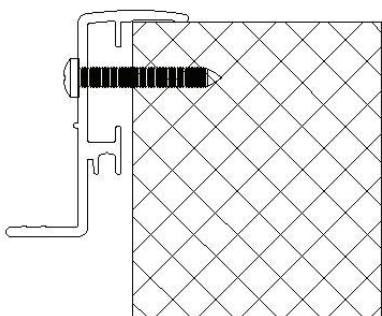
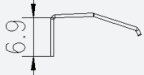
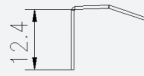



Figure 5

THICKNESS OF SIDEWALL	BRACKET TYPES	
30–36mm		Bracket 1
37–41mm		Bracket 2
42–45mm		Bracket 3

3. INSTALLATION OF THE SEAL:

To mount the seal start in the middle of the bottom frame edge of the door.

NOTE: Do not excessively bend the seal, otherwise the metal stabilization inside could be destroyed. If there are gas struts, at the gas strut brackets cut the seal as close as possible to the bracket edge. (Figure 6).

Both ends of the seal should be exactly cut and then glued. Carefully (gently) fix the seal with a rubber mallet.

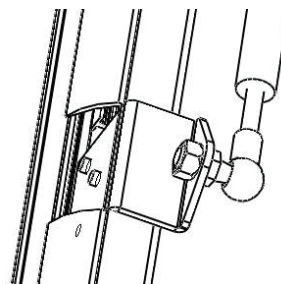
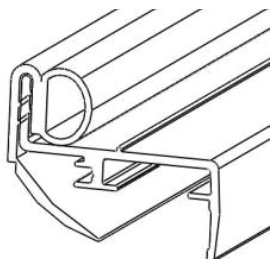

Figure 6

1300 663 868 | enquiries@aussietraveller.com.au | aussietraveller.com.au

BRISBANE SHOWROOM: 11-15 Oasis Court, Clontarf QLD 4019 | MELBOURNE SHOWROOM: 235 Barry Road, Campbellfield VIC 3061

4. INSTALLATION OF THE CLIPS: (FIGURE 7)

1. Remove the release paper from the double-sided adhesive on the clip.
2. Install the clip from direction of the arrow.

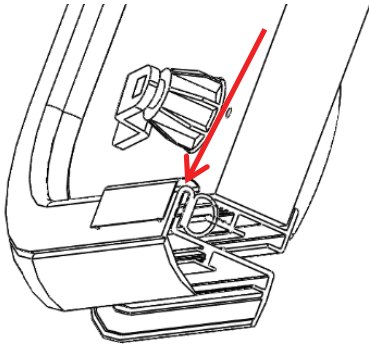

Figure 7

NOTE: If the lock is below the door, then both ends of the seal below the lock will have a cleaner appearance.

5. INSTALLATION OF THE CLIPS: (FIGURE 8)

1. Remove the release paper from the double-sided adhesive on the clip.
2. Install the clip from direction of the arrow.

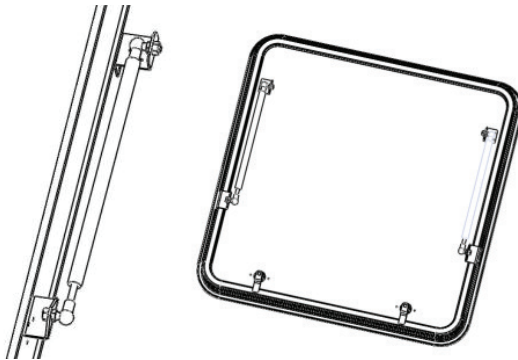

Figure 8

6. FINISHING

1. Remove excess sealant from around the door.
2. Remove the foil on the door and clean all sides of the door system.
3. Open and Close the door to ensure gas struts are positioned correctly.
4. Open and close the door handle(s) and lock and unlock using the key provided to ensure the handles are positioned correctly.

1300 663 868 | enquiries@aussietraveller.com.au | aussietraveller.com.au

BRISBANE SHOWROOM: 11-15 Oasis Court, Clontarf QLD 4019 | MELBOURNE SHOWROOM: 235 Barry Road, Campbellfield VIC 3061

WARRANTY STATEMENT

Aussie Traveller Pty Ltd ACN 642 775 460 (**Aussie Traveller**) offers the following warranty in relation to the products it supplies directly or through an authorised manufacturer, dealer or approved service repair agent (**Product**).

Australian Consumer Law

The benefits of this warranty are in addition to any rights and remedies imposed by Australian State and Federal legislation that cannot be excluded. Nothing in this warranty is to be interpreted as excluding, restricting or modifying any State or Federal legislation applicable to the supply of goods and services which cannot be excluded, restricted or modified.

If you are a consumer as defined in the Australian Consumer Law: *Our goods come with guarantees that cannot be excluded under the Australian Consumer Law. You are entitled to a replacement or refund for a major failure and compensation for any other reasonably foreseeable loss or damage. You are also entitled to have the goods repaired or replaced if the goods fail to be of acceptable quality and the failure does not amount to a major failure.*

Warranty

Aussie Traveller warrants that, subject to the exclusions and limitations below, all parts of the manufacture and assembly of the Product will be free from defects in materials and workmanship (**Warranty**) for a period of 12 months from the date of purchase as follows:

1. This Warranty is activated at the time of purchase by the final retail customer (being the owner of the Product).
2. In the event the Product is purchased by a manufacturer, dealer or approved service repair agent, this Warranty will commence at the time the final retail customer makes payment for the Product to the wholesale purchaser.
3. If the Product is purchased directly from Aussie Traveller for use by final retail customer and not to be on sold in any way, the Warranty will commence at the time of the original purchase.

Warranty Period

This Warranty cannot be assigned or transferred to a subsequent owner of the Product.

The purchaser or final retail customer should inspect the Product immediately when received or at vehicle handover, to ensure that it appears free from any damage or defect, and matches the description provided.

If after accepting the Product, a defect appears in the manufacture or assembly of the Product before the end of the Warranty Period and Aussie Traveller finds the Product to be defective in materials or workmanship, Aussie Traveller will, in its sole discretion, either:

- a. replace, repair or refund the Product or the defective part of the Product free of charge; or
- b. cause the Product or the defective part of the Product to be replaced or repaired by a qualified repairer free of charge.

In arranging Warranty inspection, service and repair, Aussie Traveller will seek to provide the details of an approved service agent within your geographic area. Should one not be available, or if the Product is in use in travel, Aussie Traveller reserves the right to seek to arrange a repair or replacement at the next available location on the route of travel.

Aussie Traveller reserves the right to replace defective parts of the Product with parts and components of similar quality, grade and composition where an identical part or component is not available.

Products presented for repair may be replaced by refurbished goods of the same type rather than being repaired. Refurbished parts may be used to repair the Product.

Aussie Traveller Awning Products

This Warranty covers specified defects in materials or workmanship for Awning Products as follows:

1. The vinyl fabric is warranted against:
 - a. holes caused by mildew (mildew will form on dust and dirt and stain fabric if fabric is not kept clean).
 - b. excessive cracking, peeling, hardening or loss of strength while used under normal conditions.
 - c. excessive fading (a slight colour change may occur due to ultraviolet rays).
2. All hardware components including the roller are warranted not to bend or break under normal use (excluding high winds, water pooling and accidents).

Making a Warranty Claim

If a defect covered by this Warranty appears, the Customer must first contact Aussie Traveller within 7 days of first becoming aware of the defect. Aussie Traveller will assist the Customer to rectify and resolve any Product issue that may arise.

When making a claim under this Warranty, Aussie Traveller requires that the following information be provided before any further action will be taken.

1. Original Invoice (Document or Number);
2. Make and model of the Product;
3. Make and model of the vehicle (if Product fitted);
4. Vehicle build date (if Product fitted);
5. Vehicle chassis number;

6. Description of damage and/or repair required;
7. Photos of the damage and/or repair; and
8. Appropriate documentation (such as historical and maintenance records).

Aussie Traveller reserves the right to request more information or images should what is provided not be sufficient to make an assessment for the Warranty claim.

The Product must be made available to Aussie Traveller or its authorised repair agent for inspection and testing. If such inspection and testing find no defect in the Product, the final retail customer must pay Aussie Traveller's usual costs of service work and testing.

The final retail customer must bear the cost of the transport of the Product to and from Aussie Traveller or the authorised repair agent, and all insurance of the Product.

Exclusions

This Warranty will not apply where:

- the Product has been repaired, altered or modified by someone other than Aussie Traveller, or without the written consent of Aussie Traveller or an authorised repair agent;
- the alleged defect in the Product is within acceptable industry tolerances and variances;
- Aussie Traveller cannot establish any fault in the Product after testing and inspection;
- the Product has been used other than for the purpose for which it was designed;
- the alleged defect in the Product has arisen due to the final retail customer's failure to properly use and
- maintain the Product in accordance with any of Aussie Traveller's instructions, recommendations and specifications (including applicable maintenance schedules);
- the alleged defect in the Product has arisen due to the final retail customer's request to customise the Product;
- the Product has been subject to abnormal conditions, including environment, temperature, high or excessive wind, water, fire, humidity, pressure, stress or similar;
- the alleged defect has arisen due to abuse, misuse, neglect or accident;
- unauthorised parts or accessories have been used on or in relation to the Product;
- the Product has been overloaded or involved in an accident;
- the alleged damage or defect has been caused by normal wear and tear;
- the alleged damage to fabric has been caused by storm, wind or rain, or stretching of fabric caused by water pooling on fabric;
- breakage or bending of hardware components has been caused by storm, wind or rain, or water pooling on fabric.

Replacement Warranty Item

If, under Warranty, a Product is replaced or repaired by Aussie Traveller or an Aussie Traveller agent, unless provided in writing to indicate otherwise, the replacement Product will carry the **remaining** Warranty terms and conditions, including length of time, of the original purchased Product.

Change of Mind

Aussie Traveller understands that at times, final retail customers may change their mind. Choose carefully as return and credit requests for items purchased by mistake or "change of mind" reasons may not be approved. Aussie Traveller will not accept Product returns under these circumstances unless by written approval by an authorized Aussie Traveller representative. If approved, an administration and restocking fee may apply.

Limitations

Aussie Traveller makes no express warranties or representations other than set out in this Warranty.

The repair or replacement of the Product or part of the Product is the absolute limit of Aussie Traveller's liability under this express Warranty.

Contact

Australia Wide: 1300 663 868

Melbourne Office
235 Barry Road
Campbellfield, Melbourne, 3061
Ph: +61 3 9357 6565
enquiries@aussietraveller.com.au

Brisbane Head Office, Factory & Showroom
11-15 Oasis Court
Clontarf, Brisbane, 4019
Ph: +61 7 3284 3284
enquiries@aussietraveller.com.au

To receive a copy of the Aussie Traveller Warranty Terms & Conditions or information regarding specific Aussie Traveller products, please contact Aussie Traveller Head Office on (07) 3284 3284 or email enquiries@aussietraveller.com.au.